

# WATER BORE INSTALLATION EQUIPMENT

## Casing Float Shoe

RIPE Float Shoes are specifically designed to suit water well applications. Non return check valves are used to prevent back flow of cement into the casing.

RIPE float shoes are made up of drillable parts, without compromising on the strength, for ease of drilling after completion has occurred.

RIPE float shoes with single or double valves can be manufactured in mild steel, stainless steel and also PVC to suit the clients application requirements.

### STANDARD SIZE RANGE INCLUDES

4", 5", 6", 8", 10", 12", 14", 16", 18", 20", 24"

OTHER SIZES AVAILABLE UPON REQUEST

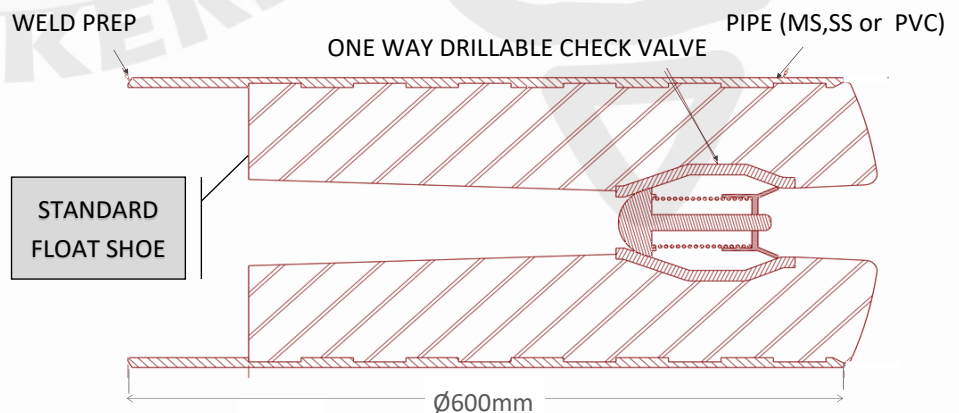
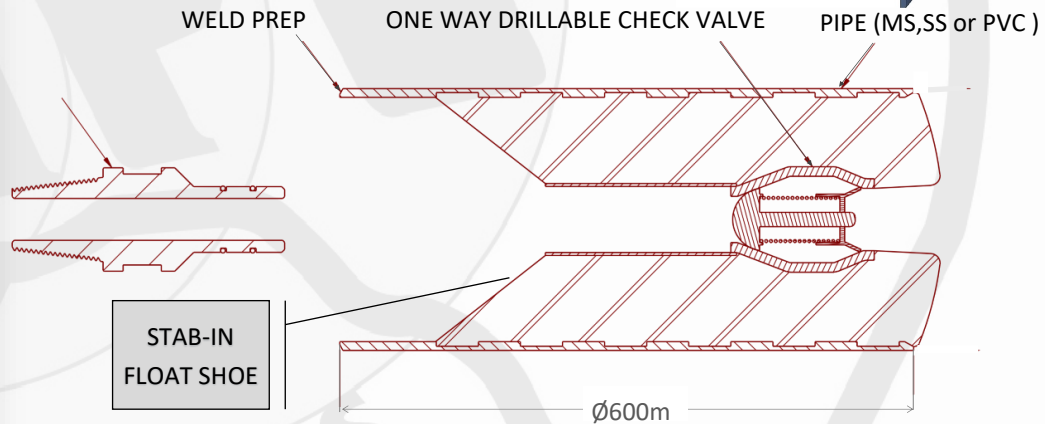
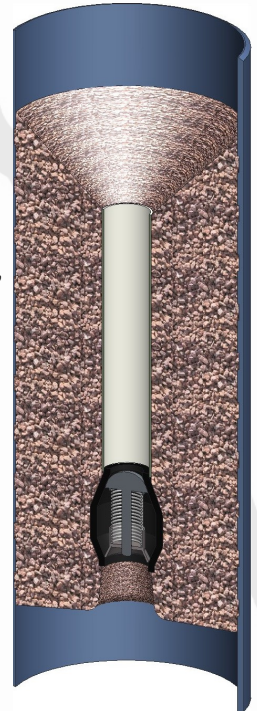

**REPLACEMENT INFLATABLE PACKERS AND ELEMENTS PTY LTD**

**29 WHEELER STREET, BELMONT, PERTH WA 6104 / CONTACT PHONE: (08) 9475 0700 / EMAIL: [packers@ripepackers.com](mailto:packers@ripepackers.com)**